

2m cable/  
optional Spiral cable 1-5m

Front board control panel  
Pick-Up/Full-Mag/Safe/De-Mag

Adjustable handle

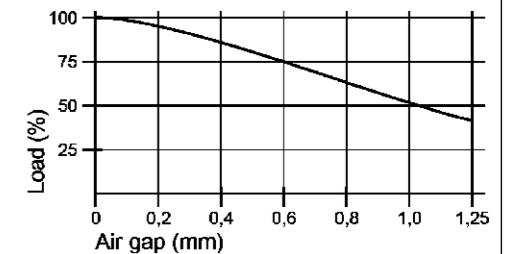
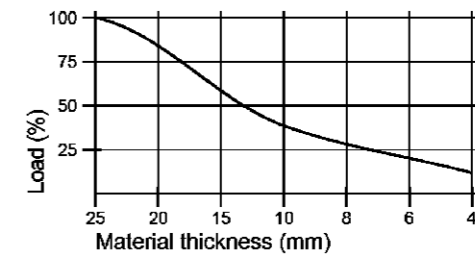
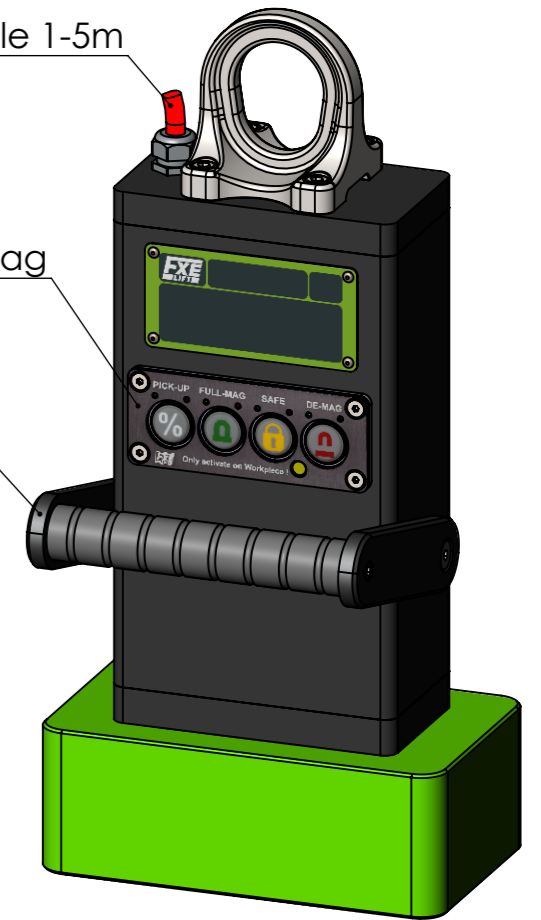

### Specification FXE 500-80

Nominative Force: 18kN	lifting capacity EN 13155/WLL		
Materialthickness >25mm (100%)	WLL= 500kg		
4,7kVA			
U: 380-480V Pulse	Protection Class IP 65		
R: 5,7Ω	Protectiv Earth SK I		
<b>Max. Load capacity at sheets and 4-edge pipes</b>			
T material thickness	Lmax (mm)	Wmax (mm)	Wll (kg)
>=8mm	1200	600	80
>=10mm	1500	1000	160
>=15mm	1500	1000	240
>=25mm	1500	1000	500

Schutzvermerk nach DIN ISO 16016 beachten!  
Nachdruck nur mit unserer Genehmigung!  
All rights reserved according to DIN ISO 16016!  
Reprint with our permission only!

3,2 / -0,05 / -0,2 tolerance  
ISO 7168 M

material: weight: 31.00

drawing no.: **0014522**

description: **FXE 500-80**

part no.: **10600502**

sheet 1 / 1

A3

scale: 1:3 Status: Freigegeben

**FLAIG**  
Magnetsysteme  
www.flraig-te.de

02	Tabellenwerte	24.10.2023	TW
rev.	change	date	name